

DROP TEST REGULATIONS AND CODES WORLDWIDE

Tech talk 60
Written by Tim O'Meagher

WHY DO WE DROP TEST

The function of the drop test is to submit tank top equipment to the dynamic forces that can result if the tank rolls onto its side. The force created by the drop test is equivalent to 5 times the force created during vehicle roll over. The objective of the drop test is to verify that no product leakage would occur in such an accident.

The drop test is applicable to any fitting on the top of a tank, which could, if it were to fail as the result of an overturn allow the liquid cargo to escape.

The drop test is a design type-test. A new design prototype is tested and once approved it need not be re-tested unless a significant design change is made.

SEE ALSO:

TECH TALK NO. 27, Manhole Covers for Petroleum Tankers

CURRENT DROP TEST REGULATIONS

There are currently only two standards worldwide in relation to drop testing, they are

1. Australian Standard AS 2809.2
Road tank vehicles for dangerous goods
Part 2: Tankers for Flammable Liquids
2. European Standard EN 13317
Tanks for the transportation of dangerous goods-
Service equipment for tanks
Manhole Cover Assembly

Note : The USA does have a drop test but it is of a different nature.
(Refer annex B)

TEST APPARATUS

The drop test apparatus comprises a vessel having on one side a mounting flange to which the device under test can be mounted. It shall have the following characteristics:

1. The dimensions, tolerances and characteristics of the drop test apparatus shall be in accordance with Annex A.
2. The stops shall be of steel and shall not incorporate any material or design feature that would tend to cushion the impact.
3. The impact zone for the stops shall be as detailed in Annex A (see detail of sand box).
4. The lifting and release equipment shall permit hoisting to, and dropping from, the two test heights of 1.2 m and 1.0 m.
5. The guides and the hoisting equipment shall not restrain free fall.
6. The design of the lifting apparatus and the operating procedures shall be in accordance with local safety regulations and shall be such as to prevent accidental dropping of the test apparatus.

Note.

- a) Equipment such as this is normally covered by industrial safety standards and may require statutory approval.
- b) Test rig is identical in its construction for both the CEN and Australian standards.

PREPARATION OF TEST COMPONENT

The component or assembly to be tested shall be fitted to a coaming, which reproduces the coaming with which the manhole will be used. If a variety of coaming designs or materials are available, then a test on the weakest combination of design and material will be considered adequate to represent the remainder of the alternatives.

The backing plate on the test rig must be of the same material type (or equivalent) and thickness as that is commonly used on tanker walkways in order to simulate normal working conditions.

CEN STANDARD TEST PROCEDURE

The CEN standard states "when testing assemblies e.g. manhole covers, that contain devices which are designed to vent at pressures less than or equal to the test pressures specified, then such devices shall be removed or blanked-off. Such devices shall be tested independently and in accordance with their own standards"

1. Mount the complete service equipment under test to the mounting flange of the drop test apparatus. The centreline of the service equipment shall be positioned on the centreline of the securing flange.
2. Fill the vessel with water, to a level of 1.3 m above the centreline of the securing flange. Plug the level indication hole and cover the top of the vessel with a plastic sheet secured with elastic rope to prevent splashes affecting the test results.
3. Hoist the apparatus to the release point, 1.2 m above rest position.
4. Stir and smooth to an even consistency the sand of the sand boxes and replace the rubber pad.
5. Drop through a vertical distance of 1.2 m.
6. Within one minute of dropping, pressurise the vessel to a pressure not less than the test pressure of the tank shell to which it shall be mounted; wipe off the service equipment and securing flange assembly and observe for leaks. (Typically the pressure is 20kPa on top of the water head to give a total pressure of approximately 35kPa)

Note: Where a leak is caused by maladjustment, the fault may be rectified and the test repeated.

Leakage from any source shall not exceed that permitted by rate B of prEN 12266-1, Table A.5. (0.3mL/minute for VOH500 Size)

Test results shall be recorded and maintained for a time period, which shall not be less than the manufactured life of the product.

AUSTRALIAN STANDARD TEST PROCEDURE

The Australian standard states that either an individual component or an assembly of components may be tested. However should any components intended to be used within an assembly e.g. emergency vents, dip fittings or pressure vacuum vents that incorporate roll over protection must be in place and fully functional for the test procedure.

1. Mount the assembly on the mounting of the drop test rig.
2. Place sufficient water in the vessel to provide a liquid head of 1.3 m on the component under test. (This must be measured from the components centre line).
3. Drop through a distance of 1.2 m
4. Observe the spray pattern from any fittings and note whether it is even. Within 1 minute of dropping wipe off any water discharged and observe for any leakage.

Note. Where a minor leak has been caused by maladjustment, the fault may be rectified and the test repeated. If there is no further leak after the re test, the test may be continued.

5. Record all failures and their nature. Any leakage subsequent to an adjustment and retest shall be considered a failure.
6. Repeat the test procedure but using a drop height of 1 metre.

Note. A leak of 10mL/Min or less would not be considered to be a significant leak.

For a list of Liquip assemblies that are drop test approved see Annex C

Annex A (normative)

Drop test apparatus

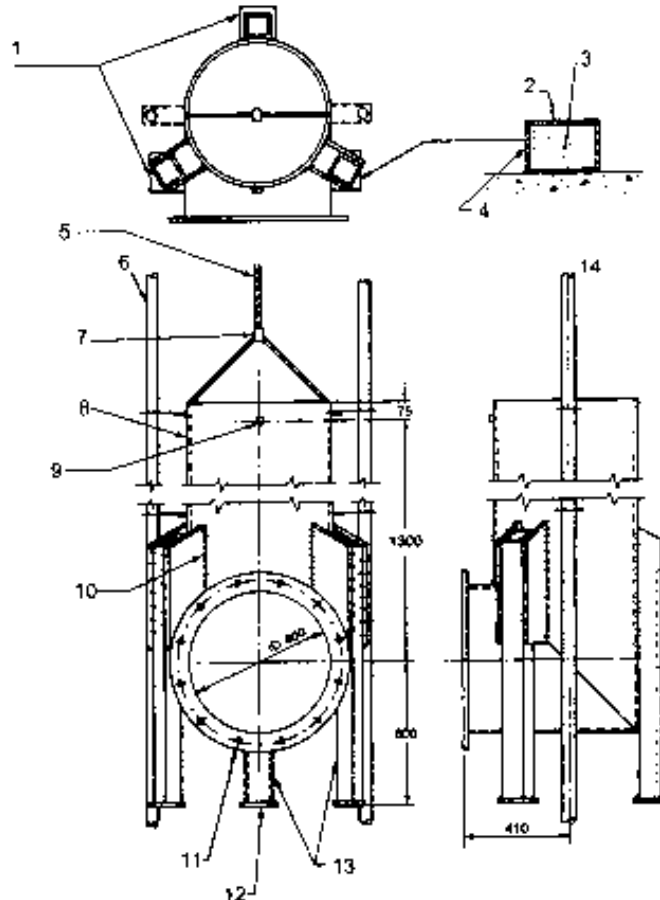

Figure A.1 – Drop test apparatus

Key

- | | | | |
|---|--|----|--|
| 1 | 3 sand boxes | 5 | Test vessel ID 600 mm \pm 10 mm, shell 8 mm thick |
| 2 | Natural rubber pad 280 mm x 280 mm \pm 5 x 25 mm thick. IRHD: 70 shore | 9 | Hole for level indication |
| 3 | Dry sand | 10 | Steel plate 10 mm thick weld as shown |
| 4 | Steel box 300 mm x 300 mm x 250 mm high, 8 mm thick, bottom fully attached | 11 | Flange OD 750 mm x 20 mm thick (min) with 12 holes \varnothing 22 mm on PCD 680 mm |
| 5 | Hoist rope | 12 | Steel plate (slop) 150 mm x 130 mm x 10 mm |
| 6 | Guide column (DN 100) | 13 | 3 support legs equally spaced, rectangular steel tube 102 mm x 78 mm x 6 mm |
| 7 | Release mechanism. All lifting equipment rated 1,5 t | 14 | Detail of one sand box |

NOTE Normal engineering tolerances will apply unless otherwise stated
Provision shall be made to pressurise the vessel in accordance with clause 6.3.4.1.g

ANNEX B – USA STANDARD

The USA MC406 standard incorporates a drop test of a different nature.

Whilst the test rig is very similar in design to the Australian and European test rigs it is applicable only to emergency vents and is designed to limit the loss of product through spray on impact. Manhole covers are not tested.

The Department of Transport (DOT) in the USA introduced a draft law incorporating the Australian drop test in the early 1990's but it was withdrawn after industry protest.

As a result a lesser test was introduced to their standard MC306 at that time. It tested static pressure to 250kPa. This test is still in place today in their current MC406 standards.

ANNEX C – LIST OF APPROVED LIQUIP ASSEMBLIES

SUMMARY OF DROP TEST APPROVALS AS OF JUNE 2010

MANHOLE REF No/SPEC	CLAMPBAND & COAMING MATERIAL No /SPEC	EMERGENCY VENT SUB ASSEMBLY No/SPEC	NOTES	STANDARD COMPLIED WITH
EH9 SERIES	ALL LISTED	ALL LISTED	SUPERSEDED SEE EH230 SERIES	Australian AS2809 Drop Test CEN 1.2 Metre Drop Test
EH230-A	ALUMINIUM	ALL SUB ASSEMBLIES LISTED FOR EH230 ASSY	REPLACES EH9 SERIES	Australian AS2809 Drop Test CEN 1.2 Metre Drop Test
EH230-M	MILD STEEL GRD 250	ALL SUB ASSEMBLIES LISTED FOR EH230 ASSY	REPLACES EH9 SERIES	Australian AS2809 Drop Test CEN 1.2 Metre Drop Test
EH230-S	STAINLESS STEEL GRD 316	ALL SUB ASSEMBLIES LISTED FOR EH230 ASSY	REPLACES EH9 SERIES	Australian AS2809 Drop Test CEN 1.2 Metre Drop Test
CH700			OBSOLETE	Australian AS2809 Drop Test
SH303				Australian AS2809 Drop Test CEN 1.2 Metre Drop Test
SH304				Australian AS2809 Drop Test CEN 1.2 Metre Drop Test
VOH100			OBSOLETE	Australian AS2809 Drop Test

MANHOLE REF No/SPEC	CLAMPBAND & COAMING MATERIAL No /SPEC	EMERGENCY VENT SUB ASSEMBLY No/SPEC	NOTES	STANDARD COMPLIED WITH
VOH200U Alum T6 SERIES	VOH200U-16 Clampband/ VOH200U-15M STEEL.GRD 250 Coaming & VOH200U-30 ALUM 5083-T0 Coaming	VOH400-2U Alum T6 Bridge only All other parts standard to all sub assemblies		Australian AS2809 Drop Test USA MC306 Pressure Test CEN 1.2 Metre Drop Test
VOH203U Alum T6 SERIES	VOH200U-16 Clampband/ VOH200U-15M STEEL.GRD 250 Coaming & VOH200U-30 ALUM 5083-T0 Coaming	VOH400-2U Alum T6 Bridge only All other parts standard to all sub assemblies		Australian AS2809 Drop Test USA MC306 Pressure Test CEN 1.2 Metre Drop Test
VOH213U Alum SERIES	VOH200U-16 Clampband/ VOH200U-15M STEEL.GRD 250 Coaming & VOH200U-15A ALUM 5005-H31Coaming	VOH200-2U Bridge only All other parts standard to all sub assemblies		NONE
VOH210U Alum SERIES	VOH200U-16 Clampband/ VOH200U-15M STEEL.GRD 250 Coaming & VOH200U-15A ALUM 5005-H31Coaming	VOH200-2U Bridge only All other parts standard to all sub assemblies		NONE
VOH220U Alum SERIES	VOH200U-16 Clampband/ VOH200U-15M STEEL.GRD 250 Coaming & VOH200U-15A ALUM 5005-H31Coaming	VOH500-2&VOH500-3 STEEL Bridge & Handle only All other parts standard to all sub assemblies		NOT TESTED
VOH223U Alum SERIES	VOH200U-16 Clampband/ VOH200U-15M STEEL.GRD 250 Coaming & VOH200U-15A ALUM 5005-H31Coaming	VOH500-2&VOH500-3 STEEL Bridge & Handle only All other parts standard to all sub assemblies		NOT TESTED
VOH200 Alum	VOH200-35 Clampband/ VOH200U-15M Steel GRD 250 coaming	VOH500-30A MILD STEEL VOH500-30U MILD STEEL		NOT TESTED

MANHOLE REF No/SPEC	CLAMPBAND & COAMING MATERIAL No /SPEC	EMERGENCY VENT SUB ASSEMBLY No/SPEC	NOTES	STANDARD COMPLIED WITH
VOH200 Alum	VOH200-35 Clampband/ VOH200U-15M Steel GRD 250 coaming	VOH500-31A FIXED BRIDGE VOH500-31U FIXED BRIDGE VOH500-32A PLAIN BRIDGE VOH500-32U PLAIN BRIDGE VOH500-33A LOCK BRIDGE VOH500-33U LOCK BRIDGE		NOT TESTED
VOH200 Alum	VOH200-35 Clampband/ VOH200U-30 Aluminium Coaming	VOH500-31A FIXED BRIDGE VOH500-31U FIXED BRIDGE VOH500-32A PLAIN BRIDGE VOH500-32U PLAIN BRIDGE VOH500-33A LOCK BRIDGE VOH500-33U LOCK BRIDGE		NOT TESTED
VOH200 Alum	VOH200-35 Clampband/ VOH200U-30 Aluminium Coaming	VOH500-30A MILD STEEL VOH500-30U MILD STEEL		NOT TESTED
VOH400 Alum T6	VOH300-16 Clampband/ VOH300-15, VOH300-15P Coamings ALUM	VOH400-2U Alum T6 Bridge only All other parts standard to all sub assemblies	SUPERSEDED SEE VOH410 SERIES	Australian AS2809 Drop Test USA MC306 Pressure Test CEN 1.2 Metre Drop Test
VOH400 Alum T6	VOH300-16 Clampband/ VOH300-17 Mild Steel Coamings GRD 250	VOH400-2U Alum T6 Bridge only All other parts standard to all sub assemblies	SUPERSEDED SEE VOH410 SERIES	NOT TESTED
VOH410 Alum T6	VOH300-16 Clampband/ VOH300-15, VOH300-15P Coamings ALUM 6065 T595	VOH400-2U Alum T6 Bridge only All other parts standard to all sub assemblies	RETESTED TO AS2809 & APPROVED APRIL 2010	Australian AS2809 Drop Test USA MC306 Pressure Test CEN 1.2 Metre Drop Test
VOH410 Alum T6	VOH300-16 Clampband/ VOH300-17 Mild Steel Coamings GRD 250	VOH400-2U Alum T6 Bridge only All other parts standard to all sub assemblies	TESTED DECEMBER 2009	Australian AS2809 Drop Test

MANHOLE REF No/SPEC	CLAMPBAND & COAMING MATERIAL No /SPEC	EMERGENCY VENT SUB ASSEMBLY No/SPEC	NOTES	STANDARD COMPLIED WITH
VOH500 Alum T6 VOH500D-1 & VOH500-1	VOH500-14M Coaming Mild Steel GRD 250	VOH500-31A FIXED BRIDGE VOH500-31U FIXED BRIDGE VOH500-32A PLAIN BRIDGE VOH500-32U PLAIN BRIDGE VOH500-33A LOCK BRIDGE VOH500-33U LOCK BRIDGE		Australian AS2809 Drop Test USA MC306 Pressure Test CEN 1.2 Metre Drop Test
VOH500 Alum T6 VOH500D-1 & VOH500-1	VOH500-14A 5005 H31 6 mm thick Rolled Coaming	VOH500-30A MILD STEEL VOH500-30U MILD STEEL	RETEST FOR CEN STANDARDS REQUIRED	NOT TESTED
VOH500 Alum T6 VOH500D-1 & VOH500-1	VOH500-14M Coaming Mild Steel GRD 250		RETEST FOR CEN STANDARDS REQUIRED	NOT TESTED
VOH500 Alum T6 VOH500D-1 & VOH500-1	VOH500-14A 5005 H31 6mm thick Rolled Coaming	VOH500-31A FIXED BRIDGE VOH500-31U FIXED BRIDGE VOH500-32A PLAIN BRIDGE VOH500-32U PLAIN BRIDGE VOH500-33A LOCK BRIDGE VOH500-33U LOCK BRIDGE		Australian AS2809 Drop Test USA MC306 Pressure Test CEN 1.2 Metre Drop Test
VOH500E Alum VOH500E-1	VOH500-14M Coaming Mild Steel GRD 250	VOH500-30A MILD STEEL VOH500-30U MILD STEEL	Special for Ethiopia	NONE
Fort Vale 859/9950 500mm Hatch Assy GRD316 Stainless Steel	STAINLESS STEEL GRD 316	NOT APPLICABLE		Australian AS2809 Drop Test USA MC306 Pressure Test UK 1 Metre Drop Test CEN 1.2 Metre Drop Test

MANHOLE REF No/SPEC	CLAMPBAND & COAMING MATERIAL No /SPEC	EMERGENCY VENT SUB ASSEMBLY No/SPEC	NOTES	STANDARD COMPLIED WITH
VOH700 Alum	NONE TESTED	VOH400-2U Alum T6 Bridge only All other parts standard to all sub assemblies	SUPERSEDED SEE VOH750 SERIES	Australian AS2809 Drop Test USA MC306 Pressure Test CEN 1.2 Metre Drop Test
VOH710 Alum	NONE TESTED	VOH400-2U Alum T6 Bridge only All other parts standard to all sub assemblies	SUPERSEDED SEE VOH750 SERIES	Australian AS2809 Drop Test USA MC306 Pressure Test CEN 1.2 Metre Drop Test
VOH710112 Alum	NONE TESTED	VOH400-2U Alum T6 Bridge only All other parts standard to all sub assemblies	SUPERSEDED SEE VOH750 SERIES	
VOH710113 Alum	NONE TESTED	VOH400-2U Alum T6 Bridge only All other parts standard to all sub assemblies	SUPERSEDED SEE VOH750 SERIES	Australian AS2809 Drop Test USA MC306 Pressure Test CEN 1.2 Metre Drop Test
VOH730 Alum	NONE TESTED	VOH400-2U Alum T6 Bridge only All other parts standard to all sub assemblies	SUPERSEDED SEE VOH750 SERIES	Australian AS2809 Drop Test USA MC306 Pressure Test CEN 1.2 Metre Drop Test
VOH750 Alum	VOH700-26 Alum 5005 H31	VOH500-30A MILD STEEL VOH500-30U MILD STEEL	RETEST FOR CEN STANDARDS REQUIRED	NONE
VOH750 Alum	VOH700-26 Alum 5005 H31	VOH500-31A FIXED BRIDGE VOH500-31U FIXED BRIDGE VOH500-32A PLAIN BRIDGE VOH500-32U PLAIN BRIDGE VOH500-33A LOCK BRIDGE VOH500-33U LOCK BRIDGE		Australian AS2809 Drop Test USA MC306 Pressure Test CEN 1.2 Metre Drop Test

VOH400	All-aluminium trim.	To Australian Standard
VOH200 Series	All-aluminium trim plus T6 cover	To Australian Standard
VOH700	All-aluminium trim plus T6 cover	To Australian Standard
SH303 and SH304	Any material	To Australian Standard
Fort Vale	859/9950, 500mm stainless steel "Rushmore"	To Australian Standard
VOH700 Series	Steel handle and bridge, as - cast cover	To UK 1.0m Test
VOH200 Series	Steel handle and bridge, as - cast cover	To UK 1.0m Test
EH9 Series	Inspection Hatches	To Australian Standard
VOH100	(no longer in production)	To Australian Standard
CH700	(no longer in production)	To Australian Standard

APPROVAL PROCEDURE

From this date, Australia has adopted self-certification and no further approvals or approval numbers will be issued by NSW Dangerous Goods. The attached Certificate of Conformity will be completed by us to provide evidence to any customers.